

# 14" Wood Cutting Band Saw

(Model 28-248)  
(Model 28-475X)

INSTRUCTION MANUAL



PART NO. 426-02-651-0055 - 06-10-03  
Copyright © 2003 Delta Machinery



To learn more about DELTA MACHINERY  
visit our website at: [www.deltamachinery.com](http://www.deltamachinery.com).

**For Parts, Service, Warranty or other Assistance,**

**please call 1-800-223-7278 (In Canada call 1-800-463-3582).**

## SAFETY GUIDELINES - DEFINITIONS

This manual contains information that is important for you to know and understand. This information relates to protecting YOUR SAFETY and PREVENTING EQUIPMENT PROBLEMS. To help you recognize this information, we use the symbols to the right. Please read the manual and pay attention to these sections.

**▲ DANGER** Indicates an imminently hazardous situation which, if not avoided, will result in death or serious injury.

**▲ WARNING** Indicates a potentially hazardous situation which, if not avoided, could result in death or serious injury.

**▲ CAUTION** Indicates a potentially hazardous situation which, if not avoided, may result in minor or moderate injury.

**CAUTION** Used without the safety alert symbol indicates potentially hazardous situation which, if not avoided, may result in property damage.

**▲ WARNING** **SOME DUST CREATED BY POWER SANDING, SAWING, GRINDING, DRILLING, AND OTHER CONSTRUCTION ACTIVITIES** contains chemicals known to cause cancer, birth defects or other reproductive harm. Some examples of these chemicals are:

- lead from lead-based paints,
- crystalline silica from bricks and cement and other masonry products, and
- arsenic and chromium from chemically-treated lumber.

Your risk from these exposures varies, depending on how often you do this type of work. To reduce your exposure to these chemicals: work in a well ventilated area, and work with approved safety equipment, always wear **MSHA/NIOSH** approved, properly fitting face mask or respirator when using such tools.

## GENERAL SAFETY RULES



**▲ WARNING** **READ AND UNDERSTAND ALL WARNINGS AND OPERATING INSTRUCTIONS BEFORE USING THIS EQUIPMENT.** Failure to follow all instructions listed below, may result in electric shock, fire, and/or serious personal injury or property damage.

### IMPORTANT SAFETY INSTRUCTIONS

Woodworking can be dangerous if safe and proper operating procedures are not followed. As with all machinery, there are certain hazards involved with the operation of the product. Using the machine with respect and caution will considerably lessen the possibility of personal injury. However, if normal safety precautions are overlooked or ignored, personal injury to the operator may result. Safety equipment such as guards, push sticks, hold-downs, featherboards, goggles, dust masks and hearing protection can reduce your potential for injury. But even the best guard won't make up for poor judgment, carelessness or inattention. Always use common sense and exercise caution in the workshop. If a procedure feels dangerous, don't try it. Figure out an alternative procedure that feels safer. **REMEMBER:** Your personal safety is your responsibility. For additional information please visit our website [www.deltamachinery.com](http://www.deltamachinery.com).

**▲ WARNING** This machine was designed for certain applications only. Delta Machinery strongly recommends that this machine not be modified and/or used for any application other than that for which it was designed. If you have any questions relative to a particular application, **DO NOT** use the machine until you have first contacted Delta to determine if it can or should be performed on the product.

**Technical Service Manager**  
**Delta Machinery**  
**4825 Highway 45 North**  
**Jackson, TN 38305**  
**(IN CANADA: 505 SOUTHGATE DRIVE, GUELPH, ONTARIO N1H 6M7)**

**▲ WARNING FAILURE TO FOLLOW THESE RULES MAY RESULT IN SERIOUS PERSONAL INJURY.**

1. **FOR YOUR OWN SAFETY, READ THE INSTRUCTION MANUAL BEFORE OPERATING THE MACHINE.** Learning the machine's application, limitations, and specific hazards will greatly minimize the possibility of accidents and injury.
2. **USE CERTIFIED SAFETY EQUIPMENT.** Eye protection equipment should comply with ANSI Z87.1 standards, hearing equipment should comply with ANSI S3.19 standards, and dust mask protection should comply with MSHA/NIOSH certified respirator standards. Splinters, air-borne debris, and dust can cause irritation, injury, and/or illness.
3. **DRESS PROPERLY.** Do not wear tie, gloves, or loose clothing. Remove watch, rings, and other jewelry. Roll up your sleeves. Clothing or jewelry caught in moving parts can cause injury.
4. **DO NOT USE THE MACHINE IN A DANGEROUS ENVIRONMENT.** The use of power tools in damp or wet locations or in rain can cause shock or electrocution. Keep your work area well-lit to prevent tripping or placing arms, hands, and fingers in danger.
5. **MAINTAIN ALL TOOLS AND MACHINES IN PEAK CONDITION.** Keep tools sharp and clean for best and safest performance. Follow instructions for lubricating and changing accessories. Poorly maintained tools and machines can further damage the tool or machine and/or cause injury.
6. **CHECK FOR DAMAGED PARTS.** Before using the machine, check for any damaged parts. Check for alignment of moving parts, binding of moving parts, breakage of parts, and any other conditions that may affect its operation. A guard or any other part that is damaged **should be properly repaired or replaced.** Damaged parts can cause further damage to the machine and/or injury.
7. **KEEP THE WORK AREA CLEAN.** Cluttered areas and benches invite accidents.
8. **KEEP CHILDREN AND VISITORS AWAY.** Your shop is a potentially dangerous environment. Children and visitors can be injured.
9. **REDUCE THE RISK OF UNINTENTIONAL STARTING.** Make sure that the switch is in the "OFF" position before plugging in the power cord. In the event of a power failure, move the switch to the "OFF" position. An accidental start-up can cause injury.
10. **USE THE GUARDS.** Check to see that all guards are in place, secured, and working correctly to prevent injury.
11. **REMOVE ADJUSTING KEYS AND WRENCHES BEFORE STARTING THE MACHINE.** Tools, scrap pieces, and other debris can be thrown at high speed, causing injury.
12. **USE THE RIGHT MACHINE.** Don't force a machine or an attachment to do a job for which it was not designed. Damage to the machine and/or injury may result.
13. **USE RECOMMENDED ACCESSORIES.** The use of accessories and attachments not recommended by Delta may cause damage to the machine or injury to the user.
14. **USE THE PROPER EXTENSION CORD.** Make sure your extension cord is in good condition. When using an extension cord, be sure to use one heavy enough to carry the current your product will draw. An undersized cord will cause a drop in line voltage, resulting in loss of power and overheating. See the Extension Cord Chart for the correct size depending on the cord length and nameplate ampere rating. If in doubt, use the next heavier gauge. The smaller the gauge number, the heavier the cord.
15. **SECURE THE WORKPIECE.** Use clamps or a vise to hold the workpiece when practical. Loss of control of a workpiece can cause injury.
16. **FEED THE WORKPIECE AGAINST THE DIRECTION OF THE ROTATION OF THE BLADE, CUTTER, OR ABRASIVE SURFACE.** Feeding it from the other direction will cause the workpiece to be thrown out a high speed.
17. **DON'T FORCE THE WORKPIECE ON THE MACHINE.** Damage to the machine and/or injury may result.
18. **DON'T OVERREACH.** Loss of balance can make you fall into a working machine, causing injury.
19. **NEVER STAND ON THE MACHINE.** Injury could occur if the tool tips, or if you accidentally contact the cutting tool.
20. **NEVER LEAVE THE MACHINE RUNNING UNATTENDED. TURN THE POWER OFF.** Don't leave the machine until it comes to a complete stop. A child or visitor could be injured.
21. **TURN THE MACHINE "OFF", AND DISCONNECT THE MACHINE FROM THE POWER SOURCE** before installing or removing accessories, before adjusting or changing set-ups, or when making repairs. An accidental start-up can cause injury.
22. **MAKE YOUR WORKSHOP CHILDPROOF WITH PADLOCKS, MASTER SWITCHES, OR BY REMOVING STARTER KEYS.** The accidental start-up of a machine by a child or visitor could cause injury.
23. **STAY ALERT, WATCH WHAT YOU ARE DOING, AND USE COMMON SENSE. DO NOT USE THE MACHINE WHEN YOU ARE TIRED OR UNDER THE INFLUENCE OF DRUGS, ALCOHOL, OR MEDICATION.** A moment of inattention while operating power tools may result in injury.
24. **THE DUST GENERATED** by certain woods and wood products can be injurious to your health. Always operate machinery in well-ventilated areas, and provide for proper dust removal. Use wood dust collection systems whenever possible.

# ADDITIONAL SAFETY RULES FOR BAND SAWS

**⚠ WARNING** FAILURE TO FOLLOW THESE RULES MAY RESULT IN SERIOUS PERSONAL INJURY.

1. **DO NOT OPERATE THIS MACHINE UNTIL** it is assembled and installed according to the instructions.
2. **OBTAIN ADVICE** from your supervisor, instructor, or another qualified person if you are not familiar with the operation of this tool.
3. **FOLLOW ALL WIRING CODES** and recommended electrical connections.
4. **USE THE GUARDS WHENEVER POSSIBLE.** Check to see that they are in place, properly adjusted, secured, and working correctly.
5. **USE PROPER BLADE SIZE** and type.
6. **ADJUST THE UPPER BLADE GUIDE** so that it is about 1/8" above the workpiece.
7. **PROPERLY ADJUST** the blade tension, tracking, blade guides, and blade support bearings.
8. **KEEP ARMS, HANDS, AND FINGERS** away from the blade.
9. **AVOID AWKWARD OPERATIONS** and hand positions where a sudden slip could cause a hand to move into the blade.
10. **NEVER START THE MACHINE** before clearing the table of all objects (tools, scrap pieces, etc.).
11. **NEVER START THE MACHINE** with the workpiece against the blade.
12. **HOLD WORKPIECE FIRMLY** against the table. DO NOT attempt to saw a workpiece that does not have a flat surface against the table.
13. **HOLD WORKPIECE FIRMLY** and feed into blade at a moderate speed.
14. **NEVER REACH UNDER THE TABLE** while the machine is running.
15. **TURN THE MACHINE "OFF"** to back out of an uncompleted or jammed cut.
16. **MAKE "RELIEF" CUTS** prior to cutting long curves.
17. **TURN THE MACHINE "OFF"** and wait for the blade to stop prior to cleaning the blade area, removing debris near the blade, removing or securing workpiece, or changing the angle of the table. A coasting blade can be dangerous.
18. **NEVER PERFORM LAYOUT, ASSEMBLY,** or set-up work on the table/work area when the machine is running.
19. **TURN THE MACHINE "OFF" AND DISCONNECT THE MACHINE** from the power source before installing or removing accessories, before adjusting or changing set-ups, or when making repairs.
20. **TURN THE MACHINE "OFF"**, disconnect the machine from the power source, and clean the table/work area before leaving the machine. **LOCK THE SWITCH IN THE "OFF" POSITION** to prevent unauthorized use.
21. **ADDITIONAL INFORMATION** regarding the safe and proper operation of power tools (i.e. a safety video) is available from the Power Tool Institute, 1300 Sumner Avenue, Cleveland, OH 44115-2851 ([www.powertoolinstitute.com](http://www.powertoolinstitute.com)). Information is also available from the National Safety Council, 1121 Spring Lake Drive, Itasca, IL 60143-3201. Please refer to the American National Standards Institute ANSI 01.1 Safety Requirements for Woodworking Machines and the U.S. Department of Labor OSHA 1910.213 Regulations.

**SAVE THESE INSTRUCTIONS.**

**Refer to them often and use them to instruct others.**

## POWER CONNECTIONS

A separate electrical circuit should be used for your machines. This circuit should not be less than #12 wire and should be protected with a 20 Amp time lag fuse. If an extension cord is used, use only 3-wire extension cords which have 3-prong grounding type plugs and matching receptacle which will accept the machine's plug. Before connecting the machine to the power line, make sure the switch is in the "OFF" position and be sure that the electric current is of the same characteristics as indicated on the machine. All line connections should make good contact. Running on low voltage will damage the machine.

**⚠ DANGER DO NOT EXPOSE THE MACHINE TO RAIN OR OPERATE THE MACHINE IN DAMP LOCATIONS.**

## MOTOR SPECIFICATIONS

Your machine is wired for 120 volt, 60 HZ alternating current. Before connecting the machine to the power source, make sure the switch is in the "OFF" position.

## GROUNDING INSTRUCTIONS

**⚠ DANGER THIS MACHINE MUST BE GROUNDED WHILE IN USE TO PROTECT THE OPERATOR FROM ELECTRIC SHOCK.**

### 1. All grounded, cord-connected machines:

In the event of a malfunction or breakdown, grounding provides a path of least resistance for electric current to reduce the risk of electric shock. This machine is equipped with an electric cord having an equipment-grounding conductor and a grounding plug. The plug must be plugged into a matching outlet that is properly installed and grounded in accordance with all local codes and ordinances.

Do not modify the plug provided - if it will not fit the outlet, have the proper outlet installed by a qualified electrician.

Improper connection of the equipment-grounding conductor can result in risk of electric shock. The conductor with insulation having an outer surface that is green with or without yellow stripes is the equipment-grounding conductor. If repair or replacement of the electric cord or plug is necessary, do not connect the equipment-grounding conductor to a live terminal.

Check with a qualified electrician or service personnel if the grounding instructions are not completely understood, or if in doubt as to whether the machine is properly grounded.

Use only 3-wire extension cords that have 3-prong grounding type plugs and matching 3-conductor receptacles that accept the machine's plug, as shown in Fig. A.

Repair or replace damaged or worn cord immediately.

### 2. Grounded, cord-connected machines intended for use on a supply circuit having a nominal rating less than 150 volts:

If the machine is intended for use on a circuit that has an outlet that looks like the one illustrated in Fig. A, the machine will have a grounding plug that looks like the plug illustrated in Fig. A. A temporary adapter, which looks like the adapter illustrated in Fig. B, may be used to connect this plug to a matching 2-conductor receptacle as shown in Fig. B if a properly grounded outlet is not available. The temporary adapter should be used only until a properly grounded outlet can be installed by a qualified electrician. The green-colored rigid ear, lug, and the like, extending from the adapter must be connected to a permanent ground such as a properly grounded outlet box. Whenever the adapter is used, it must be held in place with a metal screw.

**NOTE: In Canada, the use of a temporary adapter is not permitted by the Canadian Electric Code.**

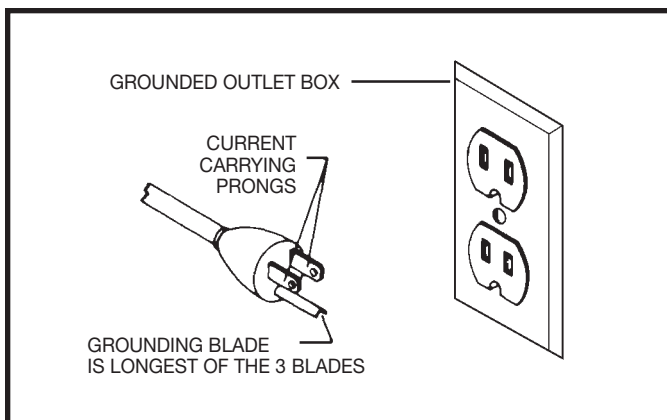

Fig. A

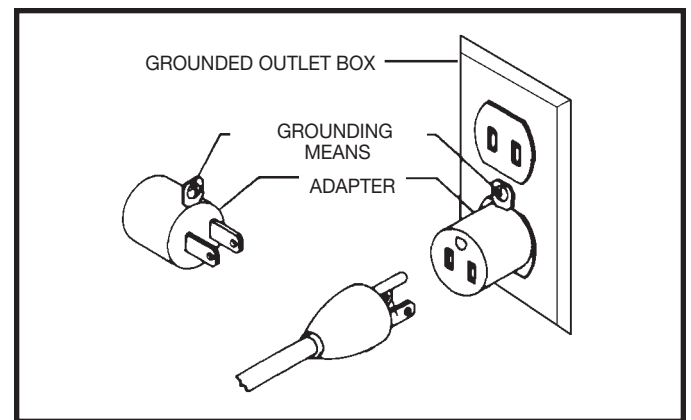

Fig. B

3. Grounded, cord-connected machines intended for use on a supply circuit having a nominal rating between 150 - 250 volts, inclusive:

If the machine is intended for use on a circuit that has an outlet that looks like the one illustrated in Fig. C, the machine will have a grounding plug that looks like the plug illustrated in Fig. C. Make sure the machine is connected to an outlet having the same configuration as the plug. No adapter is available or should be used with this machine. If the machine must be re-connected for use on a different type of electric circuit, the re-connection should be made by qualified service personnel; and after re-connection, the machine should comply with all local codes and ordinances.

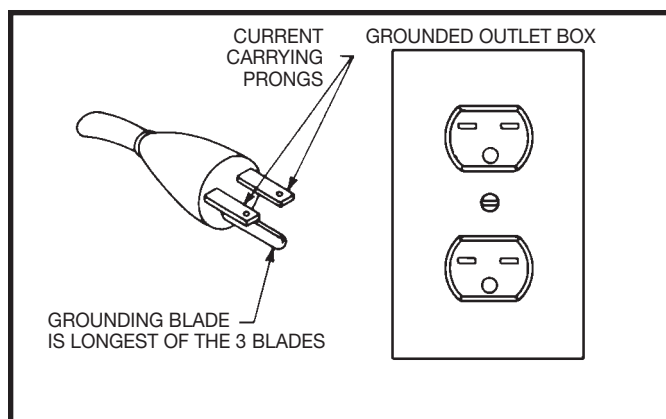

Fig. C

**⚠ DANGER** IN ALL CASES, MAKE CERTAIN THE RECEPTACLE IN QUESTION IS PROPERLY GROUNDED. IF YOU ARE NOT SURE HAVE A QUALIFIED ELECTRICIAN CHECK THE RECEPTACLE.

## EXTENSION CORDS

**CAUTION** Use proper extension cords. Make sure your extension cord is in good condition and is a 3-wire extension cord which has a 3-prong grounding type plug and matching receptacle which will accept the machine's plug. When using an extension cord, be sure to use one heavy enough to carry the current of the machine. An undersized cord will cause a drop in line voltage, resulting in loss of power and overheating. Fig. D, shows the correct gauge to use depending on the cord length. If in doubt, use the next heavier gauge. The smaller the gauge number, the heavier the cord.

MINIMUM GAUGE EXTENSION CORD			
RECOMMENDED SIZES FOR USE WITH STATIONARY ELECTRIC MACHINES			
Ampere Rating	Volts	Total Length of Cord in Feet	Gauge of Extension Cord
0-6	120	up to 25	18 AWG
0-6	120	25-50	16 AWG
0-6	120	50-100	16 AWG
0-6	120	100-150	14 AWG
6-10	120	up to 25	18 AWG
6-10	120	25-50	16 AWG
6-10	120	50-100	14 AWG
6-10	120	100-150	12 AWG
10-12	120	up to 25	16 AWG
10-12	120	25-50	16 AWG
10-12	120	50-100	14 AWG
10-12	120	100-150	12 AWG
12-16	120	up to 25	14 AWG
12-16	120	25-50	12 AWG
12-16	120	GREATER THAN 50 FEET NOT RECOMMENDED	

Fig. D

MINIMUM GAUGE EXTENSION CORD			
RECOMMENDED SIZES FOR USE WITH STATIONARY ELECTRIC MACHINES			
Ampere Rating	Volts	Total Length of Cord in Feet	Gauge of Extension Cord
0-6	240	up to 50	18 AWG
0-6	240	50-100	16 AWG
0-6	240	100-200	16 AWG
0-6	240	200-300	14 AWG
6-10	240	up to 50	18 AWG
6-10	240	50-100	16 AWG
6-10	240	100-200	14 AWG
6-10	240	200-300	12 AWG
10-12	240	up to 50	16 AWG
10-12	240	50-100	16 AWG
10-12	240	100-200	14 AWG
10-12	240	200-300	12 AWG
12-16	240	up to 50	14 AWG
12-16	240	50-100	12 AWG
12-16	240	GREATER THAN 100 FEET NOT RECOMMENDED	

Fig. D

## FUNCTIONAL DESCRIPTION

### FOREWORD

Delta Models 28-248 and the 28-475X are 14" wood cutting band saws. The band saws have a quick tensioning blade mechanism for ease with changing blades and applying tension to the blade. The Delta Models 28-248 and 28-475X have large 16"x16" cast iron tables that can be tilted 45 degrees to the right and 8 degrees to the left. The band saws also come with a 4" O.D. dust port for connecting the band saws to a dust collector.

**NOTICE: THE MANUAL COVER PHOTO ILLUSTRATES THE CURRENT PRODUCTION MODEL. ALL OTHER ILLUSTRATIONS ARE REPRESENTATIVE ONLY AND MAY NOT DEPICT THE ACTUAL COLOR, LABELING OR ACCESSORIES AND MAY BE INTENDED TO ILLUSTRATE TECHNIQUE ONLY.**

# UNPACKING AND CLEANING

Carefully unpack the machine and all loose items from the shipping container(s). Remove the protective coating from all unpainted surfaces. This coating may be removed with a soft cloth moistened with kerosene (do not use acetone, gasoline or lacquer thinner for this purpose). After cleaning, cover the unpainted surfaces with a good quality household floor paste wax.

1. Remove the cardboard box from around the packing skid (A) Fig. 2.
2. Remove the two bolts (B) Fig. 2, with a 3/8" wrench, that attach the motor to the packing skid (A)

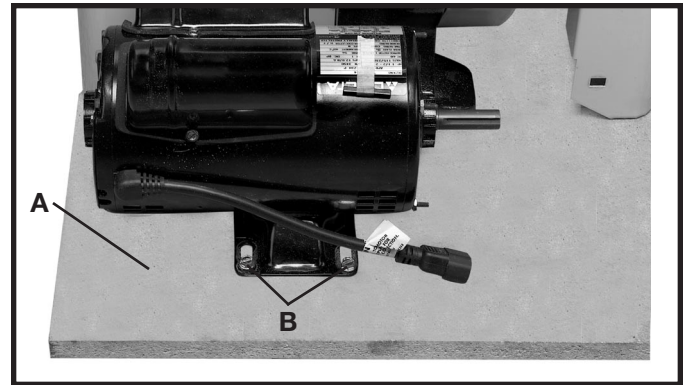

Fig. 2

3. Remove the bolts that attach the stand (C) Fig. 3, and the saw (D) to the the packing skid (A) with a 1/2" wrench.

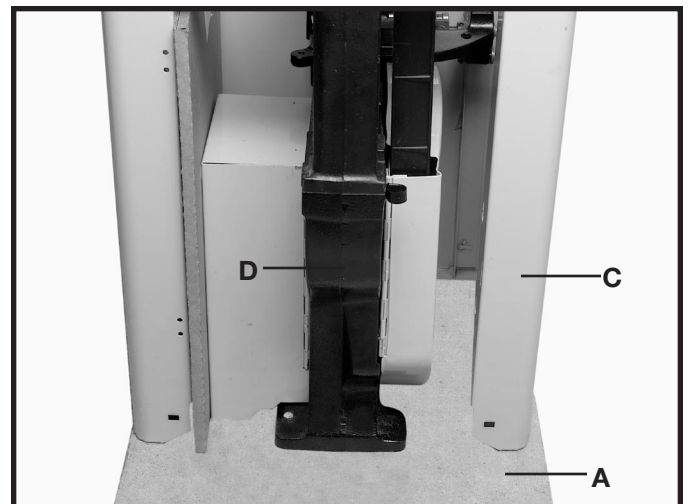

Fig. 3

# BAND SAW PARTS

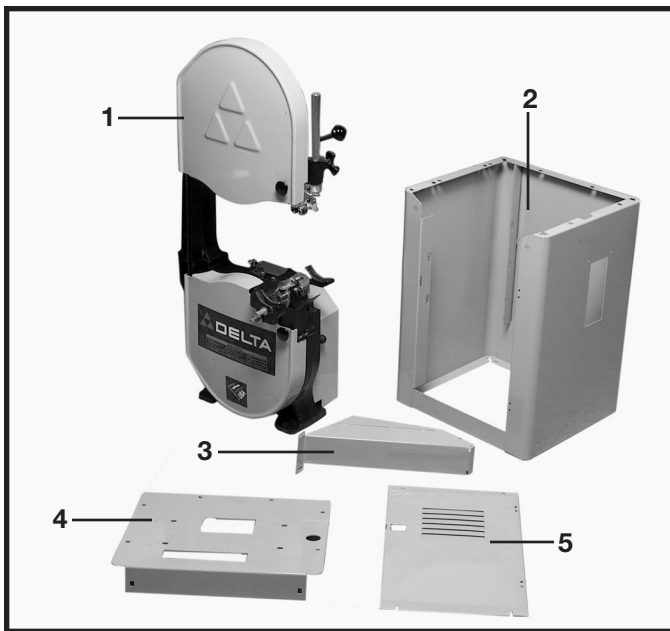

Fig. 4

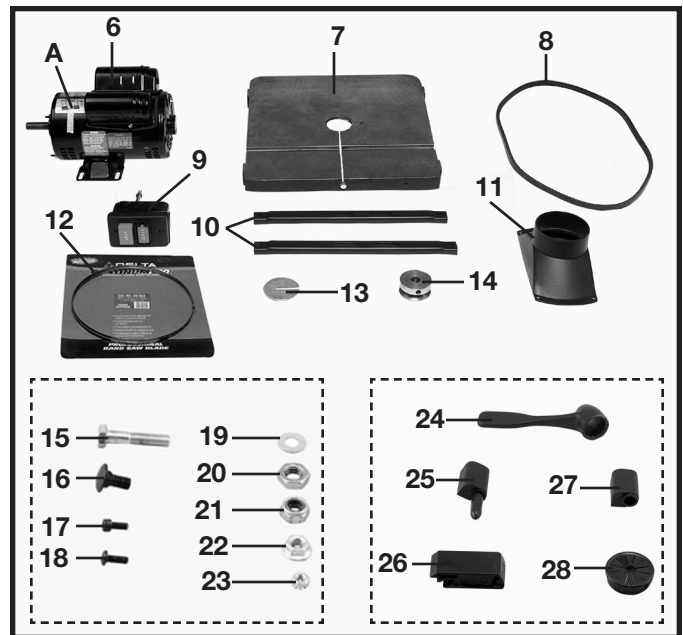

Fig. 5

1. Saw
2. Stand
3. Dust Chute
4. Top Plate
5. Stand Door
6. Motor and key (A)
7. Table
8. Belt
9. On/Off Switch
10. Motor Bracket (2)
11. Dust Spout
12. Blade
13. Table Insert
14. Motor Pulley

15. 5/16-18x1½" Hex Head Screw (4)
16. 5/16-18x¾" Carriage Head Bolt (16)
17. #10-24x1/2" Socket Head Cap Screw (8)
18. #10-32x1/2" Pan Head Screw (4)
19. 5/16" Flat Washer (4)
20. 7/16" Jam Nut (2)
21. 7/16" Locknut (2)
22. 5/16-18 Hex Nut (20)
23. #10-32 Hex Nut (4)
24. Table Handle (2)
25. Hinge Catch (2)
26. Door Latch
27. Hinge (2)
28. Cord Bushing



# ASSEMBLY

**⚠ WARNING** FOR YOUR OWN SAFETY, DO NOT CONNECT THE MACHINE TO THE POWER SOURCE UNTIL THE MACHINE IS COMPLETELY ASSEMBLED AND YOU READ AND UNDERSTAND THE ENTIRE INSTRUCTION MANUAL.

## MOTOR BRACKET TO STAND

1. Place the stand base on its side as shown in Fig. 6.
2. Align the two holes in the motor bracket (A) Fig. 7, with the two holes in the stand. **NOTE: ATTACH MOTOR BRACKETS TO HOLES #1 AND 3 IN FRONT STAND FLANGE (D) FIG. 6, AND HOLES #2 AND 4 IN BACK STAND FLANGE (E).**

**NOTE: MAKE SURE THE SLOTS (C) FIG. 7, IN THE MOTOR BRACKET (A), ARE POSITIONED CLOSER TO THE OPENING OF THE STAND (D) THAN THE BACK PANEL (E) OF THE STAND.**

3. Insert a 5/16-18x3/4" carriage head bolt through the hole in the motor bracket (A) Fig. 7, and the hole in the stand.
4. Thread a 5/16-18 hex nut onto the screw and tighten securely.
5. Repeat this process for the remaining hole in the motor bracket.
6. Attach the other motor bracket to the stand in the same manner.

## MOTOR TO MOTOR BRACKET

1. Place the motor (A) Fig. 8, on the motor brackets (B). Align the holes in the motor with the holes on the motor bracket.
2. Insert a 5/16-18x3/4" carriage head bolt through the hole in the motor bracket and the hole in the motor.
3. Thread a 5/16-18 hex nut on to the screw. **NOTE: DO NOT COMPLETELY TIGHTEN THE BOLT AND NUT AT THIS TIME.**
4. Repeat this process for the three remaining holes in the motor and motor bracket.
5. Place stand on its base as shown in Fig. 9.

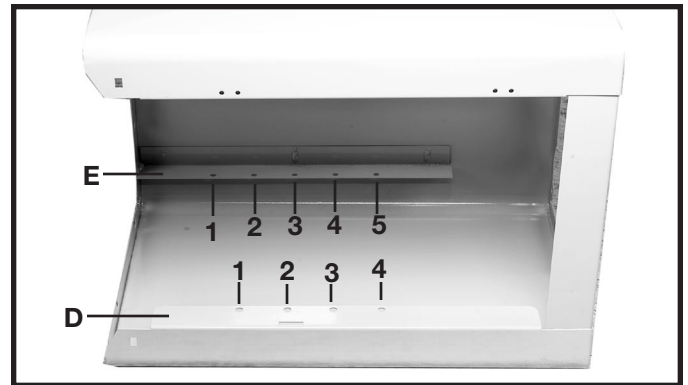

Fig. 6

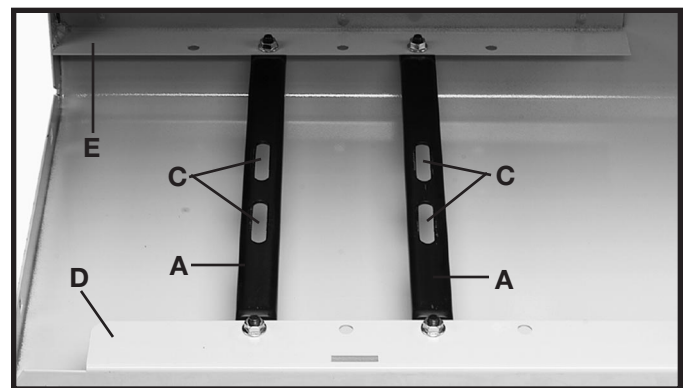

Fig. 7

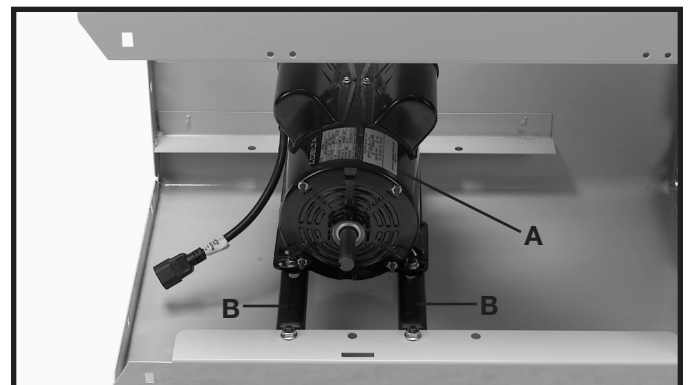

Fig. 8



Fig. 9

## TOP PLATE TO STAND

1. Place the top plate (A) Fig. 10, on the top of the stand (B).
2. Align the six square holes on the top plate (A) Fig. 10, with the six square holes in the stand (B).
3. Align the two square holes on the side of the plate (A) Fig. 10, with the two square holes on the side of the stand (B).
4. Insert a 5/16-18x3/4" carriage head bolt through the top plate and the stand. Thread a 5/16-18 hex nut on to screw.
5. Repeat this process for the five remaining holes in the top of the plate and stand, and the two holes in the side of the top plate and the stand. Make sure the door opening is at least 13" wide before tightening the screws.

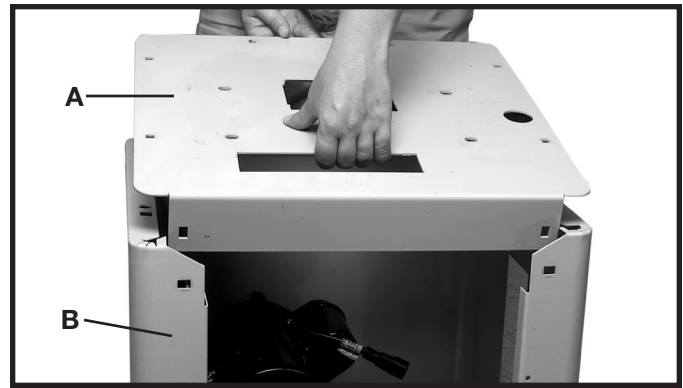

Fig. 10



Fig. 11

## DUST CHUTE

1. Insert the dust chute from inside the stand through the opening (A) Fig. 11, in the top of the stand.  
**NOTE: MAKE SURE THE TAB (B) FIG. 12, IN THE DUST CHUTE, ENGAGES THE CUTOUT (C) IN THE TOP OF THE STAND.**
2. Align the two slotted holes (D) Fig. 13, in the bottom of the dust chute with the two holes (E) Fig. 14, in the stand.

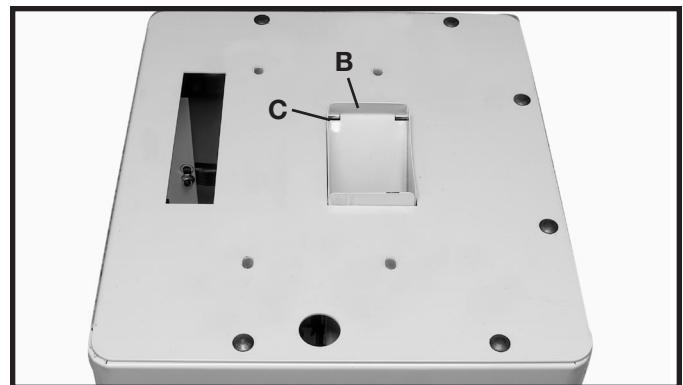

Fig. 12

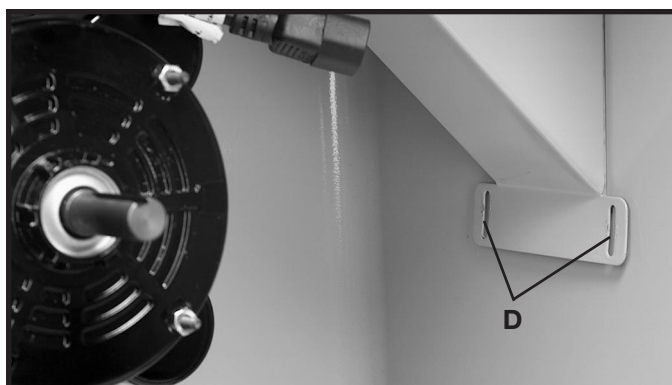

Fig. 13

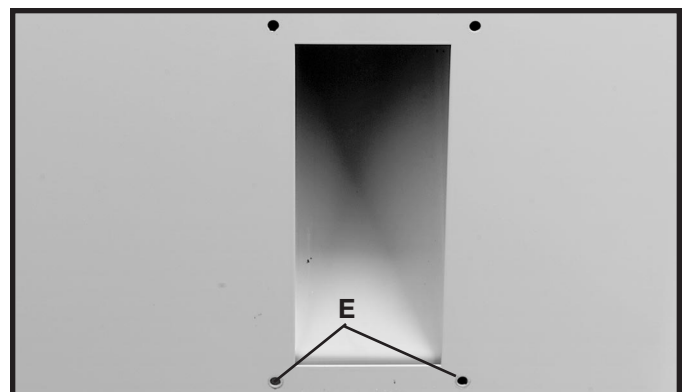

Fig. 14

## **BAND SAW USED WITH A DUST COLLECTOR**

3. If you are going to use your band saw with a dust collector, attach the dust port as follows:

- A. Align the four holes in the dust port (A) Fig. 15, with the four holes in the side of the stand.
- B. Insert a #10-32x1/2" pan head screw through the two holes in the dust port (B) Fig. 15, and stand. Thread a #10-32 hex nut onto the screw, and tighten securely.
- C. Repeat this process for the two remaining holes (C) in the dust port, stand, and dust chute.  
**NOTE: THE DUST CHUTE WILL ONLY BE ATTACHED WITH THE TWO BOTTOM HOLES (C) IN THE DUST PORT.**

## **BAND SAW USED WITHOUT A DUST COLLECTOR**

3. If you are not going to use a dust collector with your band saw proceed as follows:

- A. Insert a #10-32x1/2" pan head screw through hole (A) Fig. 16, in the stand and dust chute. Thread a #10-32 hex nut onto the screw, and tighten securely.
- B. Repeat this process for the remaining holes in the stand. **NOTE: THE DUST CHUTE WILL ONLY BE ATTACHED WITH THE TWO BOTTOM HOLES IN THE STAND.**

## **STAND DOOR TO STAND**

1. Align the two holes in the hinge catch (A) Fig. 17, with the two holes on the stand. **NOTE: MAKE SURE THE HINGE CATCH (A) IS POINTED UP AS SHOWN IN FIG. 17.**

2. Insert a #10-24x1/2" socket head cap screw through the hole in the stand, (from the inside of the stand), and thread the screw into the hinge catch. Repeat this process for the remaining hole in the stand and hinge catch. **NOTE: DO NOT COMPLETELY TIGHTEN THE SCREWS AT THIS TIME.**

3. Attach the other hinge catch in the same manner.

4. Make sure the two hinge catches are aligned with each other by using a straight edge as shown in Fig18.

5. Tighten the four screws securely, that attach the hinge catches to the stand.

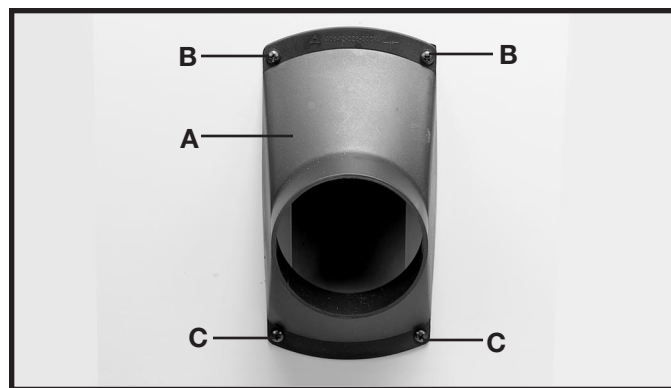

Fig. 15

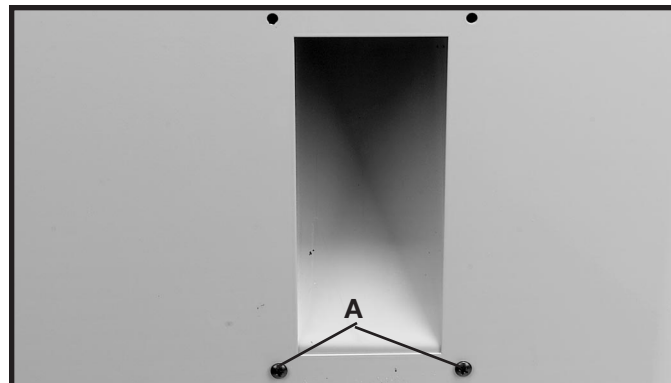

Fig. 16



Fig. 17

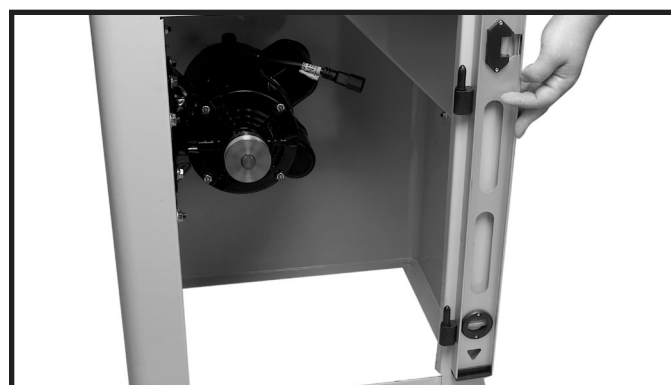

Fig. 18

6. Align the two holes in the hinge (C) Fig. 19, with the two holes in the stand door (D). **MAKE SURE THAT THE HINGE OPENING IS POINTING DOWN.**

7. Insert a #10-24x1/2" socket head cap screw through the hole in the door, and thread the screw into the hole in the hinge. Repeat this process for the remaining hole in the door and the hinge. **NOTE: DO NOT COMPLETELY TIGHTEN THE SCREWS AT THIS TIME.**

8. Repeat this process for the remaining hinge.

9. Make sure the two hinges are aligned with each other by using a straight edge as shown in Fig. 20.

10. Tighten the four screws securely, that attach the hinges to the door.

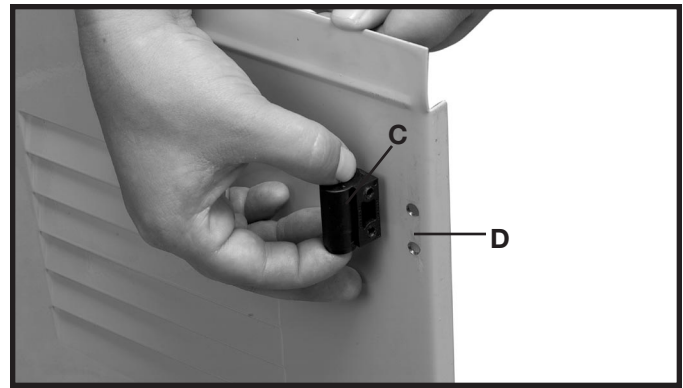

Fig. 19



Fig. 20

11. Slide the two hinges (C) Fig. 21, on the door, over the two hinge catches (A) on the stand.

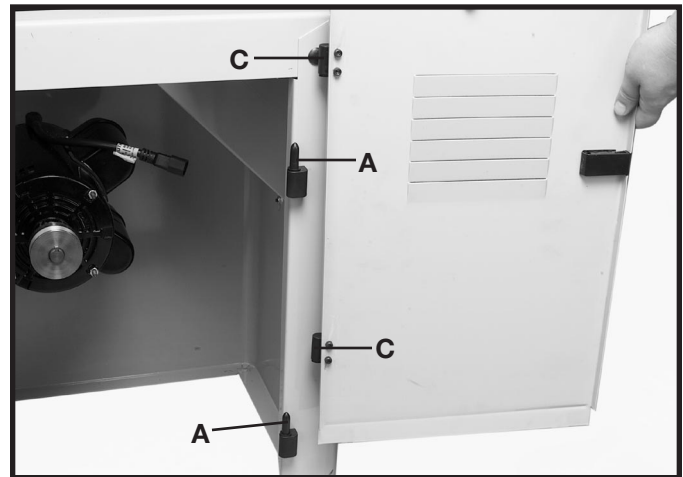

Fig. 21

12. Insert the door latch (F) Fig. 22, from the outside, through the hole in the door.

13. Push down on the door latch to snap the latch in place.

14. To open or shut the door, slide the latch away from the cabinet and pull or push the door.

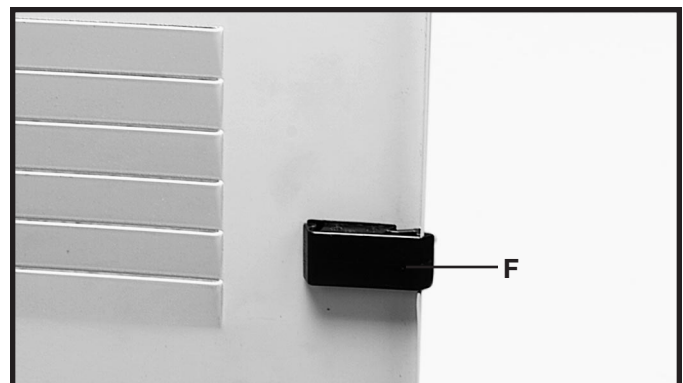

Fig. 22

# SAW TO STAND

**⚠ CAUTION** THE BAND SAW IS VERY HEAVY. USE A HELPER WHEN ATTACHING THE SAW TO THE STAND.

1. Place the band saw on top of the stand as shown in Fig. 23. **NOTE: MAKE SURE THE PULLEY (A) FIG. 23, IS ON THE SIDE OF THE STAND WITH THE BELT OPENING (B).**
2. Align the four holes in the saw with the four holes in the top of the stand.
3. Place a 5/16" flat washer onto a 5/16-18x1½" hex head screw. Insert the screw through the hole (C) in the saw and the stand.
4. Thread a 5/16-18 hex nut onto the screw.
5. Repeat this process for the three remaining holes in the saw and the stand and tighten securely.

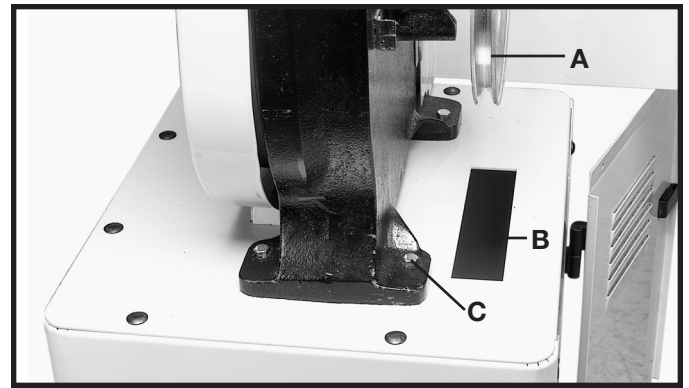

Fig. 23

# MOTOR PULLEY

1. Remove the pulley key (A) Fig. 5, that is taped to the motor.
2. Place the pulley key (A) Fig. 24, in the slot (B) on the motor shaft.
3. Align the slot in the motor pulley (C) Fig. 24, with the key (A), on the motor shaft.
4. Slide the motor pulley (C) Fig. 24, on to the motor shaft, and tighten set screw (D) Fig. 24, on the pulley against the key (A) on the motor shaft.

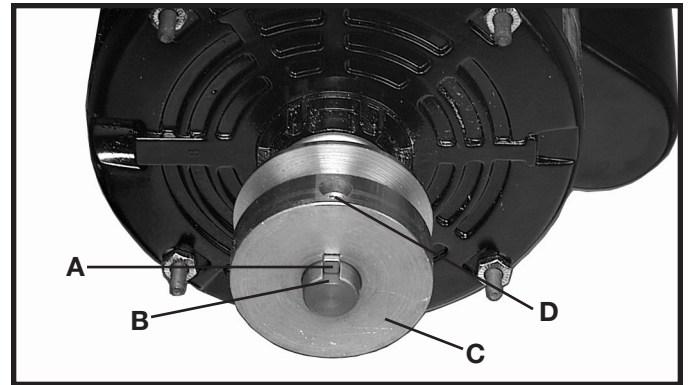

Fig. 24

# BELT TO SAW AND MOTOR PULLEY

1. Place the belt over the saw pulley (A) Fig. 25.
2. Lift the motor and place the other end of the belt around the motor pulley (B) Fig. 26.
3. Check the alignment of the motor and saw pulley with a straight edge (C) Fig. 26. Adjust the position of the motor pulley, until the motor pulley and saw pulley are aligned.
4. Push down on the motor so that there is approximately a 1/4" deflection when pushing in on the center of the belt.
5. Tighten the four bolts that hold the motor to the motor bracket.

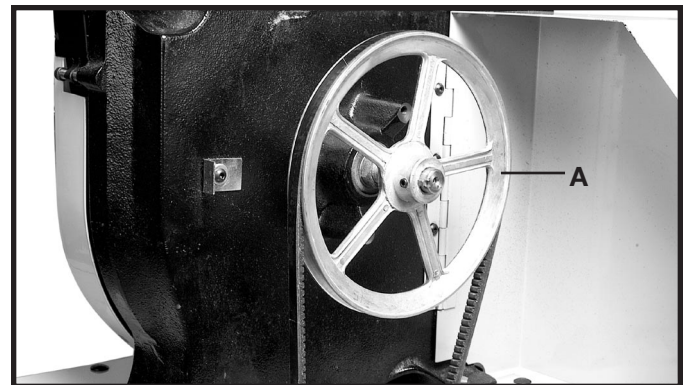

Fig. 25

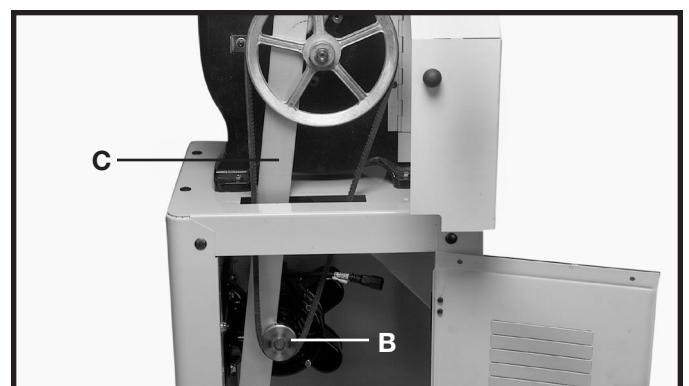

Fig. 26

# TABLE TO SAW

1. Align the two table studs (A) Fig. 27, in the bottom of the table, with the two holes in the trunnion assemblies (B). Place table on trunnion assemblies. **NOTE: MAKE SURE THE SLOT (C) FIG. 27, IN THE TABLE IS FACING AWAY FROM THE ARM (D).**

2. Thread a 7/16" jam nut (C) Fig. 28 onto each table stud and tighten securely.

3. Place the table handle (H) on each stud as shown in Fig. 29. **NOTE: MAKE SURE THE TABLE HANDLES ARE POSITIONED AS SHOWN IN FIG. 29, SO THAT THE TABLE CAN BE TIGHTENED AND LOOSENED.**

4. Thread a 7/16" locknut (D) Fig. 30, onto each stud. Tighten each locknut up to the table handle and then loosen each locknut a 1/2 of turn.

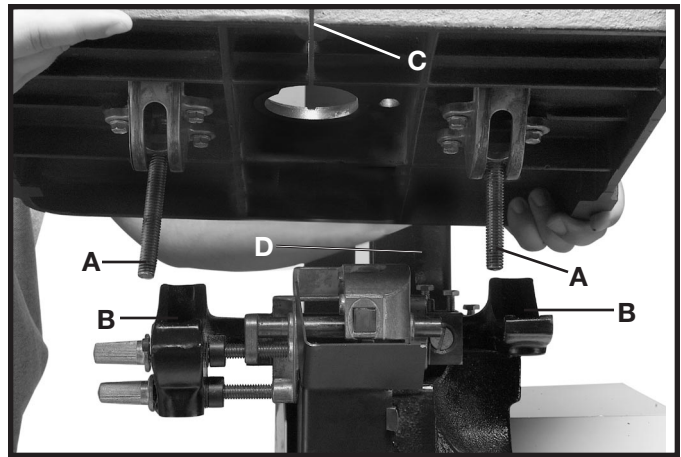

Fig. 27

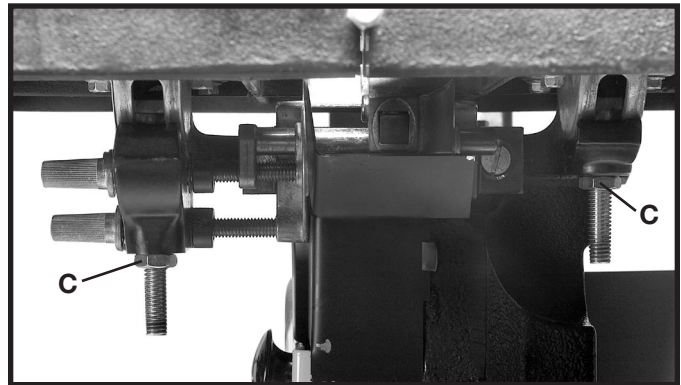

Fig. 28

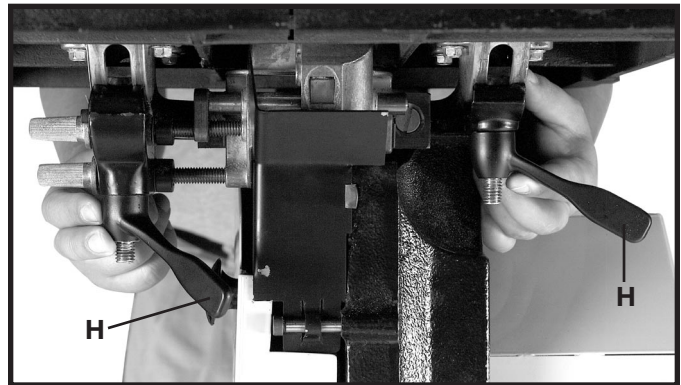

Fig. 29

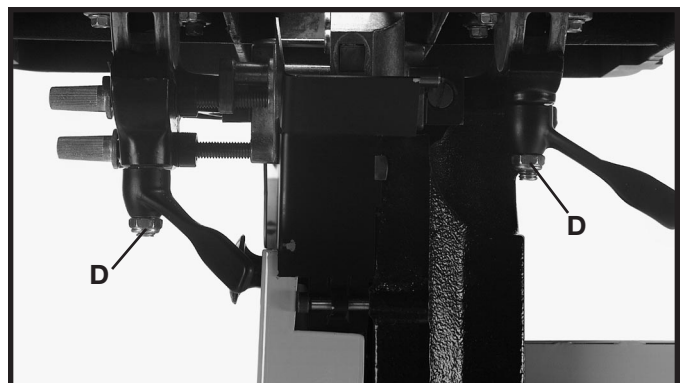

Fig. 30

# BLADE TO SAW

**CAUTION** THE 14" BAND SAW USES 93½" LENGTH BLADES.

1. Remove the table pin (A) Fig. 31 from the table.
2. Open the two wheel guard doors (B) Fig. 31, and the blade guard door (C).
3. Make sure the quick tension lever (D) Fig. 31, is positioned to the right of the machine, to relieve tension as shown.
4. **NOTE: CHECK BLADE TO BE SURE TEETH WILL POINT DOWN TOWARD TABLE WHEN INSTALLED. IF NOT, TURN BLADE INSIDE OUT.** Slide the band saw blade, (teeth facing out), through the slot (E) Fig. 31, in the band saw table.
5. Place the blade around the two wheel assemblies (A) Fig. 32.
6. Replace the table pin (A) Fig. 31.
7. Close the two wheel guard doors (B) Fig. 31, and the blade guard door (C).
8. Move the quick tension lever (D) Fig. 32, to the left position to put tension on the blade as shown.
9. See the section “**OPERATING CONTROLS AND ADJUSTMENTS**” to adjust blade tension and tracking.

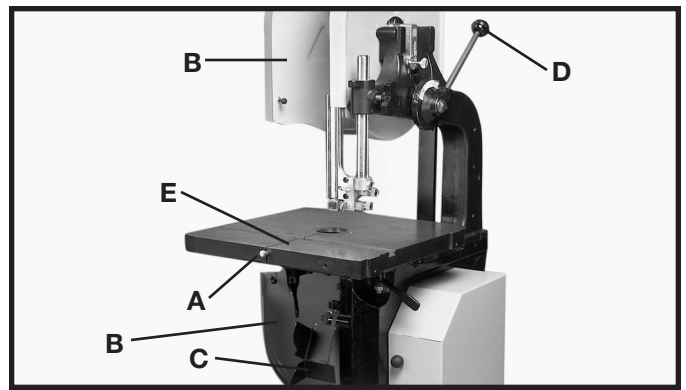

Fig. 31

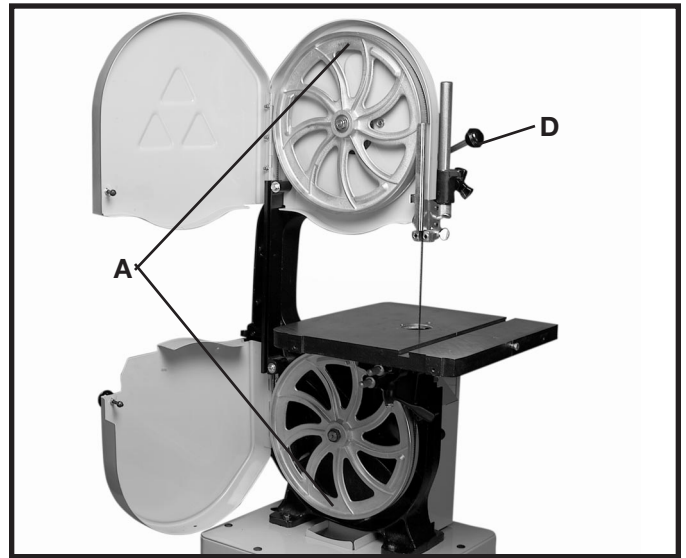

Fig. 32

# TABLE INSERT

Place table insert (A) Fig. 33, in opening of table. **NOTE:** A tab (B) is provided on insert that engages with notch (C) in table opening.

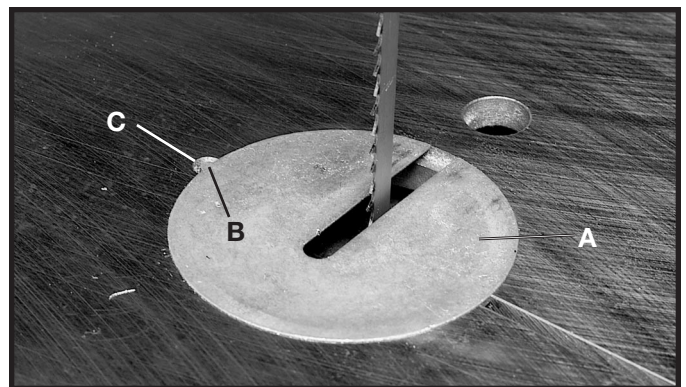

Fig. 33

# ON / OFF SWITCH TO STAND

1. Remove the two outer hex nuts and lock washers (A) Fig. 34 from the two screws extending out from the back of the switch box (B).



Fig. 34

2. Insert two screws (C) Fig. 35, located on back of switch box, into two holes (D) located in the band saw arm.

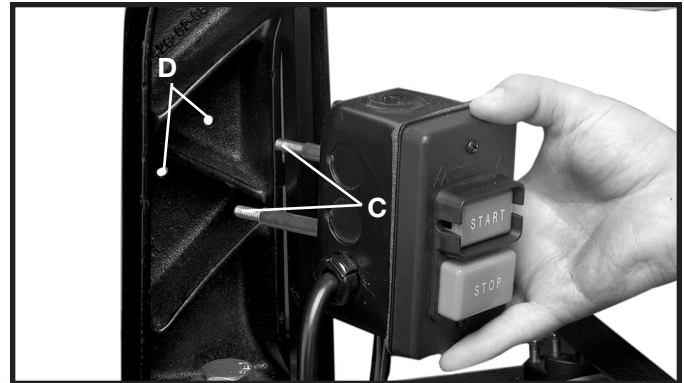

Fig. 35

3. Use the two nuts and lockwashers (L) Fig. 36, removed in **STEP 1**, to fasten the switch box to the bandsaw arm.

4. Remove the screw and cable clamp (E) Fig. 37 from the lower arm of the band saw.

5. Insert the switch cord and power cord (F) Fig. 37 into the clamp (E) (removed in **STEP 4**), and fasten to the bandsaw.

6. Insert the cord bushing into hole (G) Fig. 38, on the top of the band saw stand.

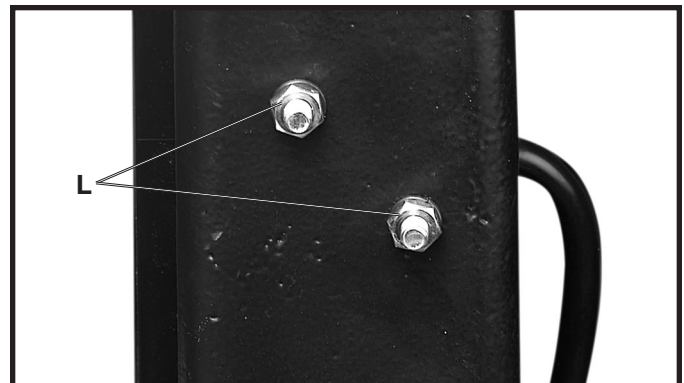

Fig. 36

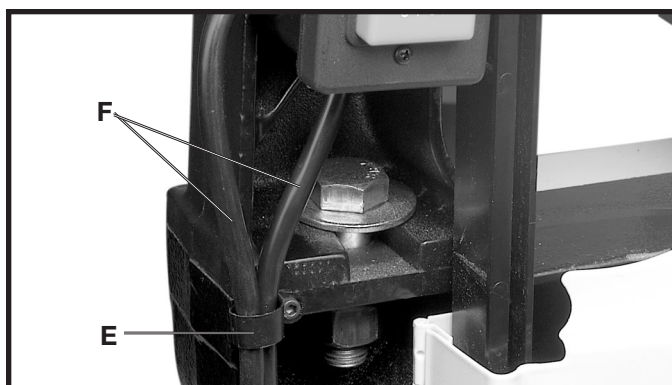

Fig. 37

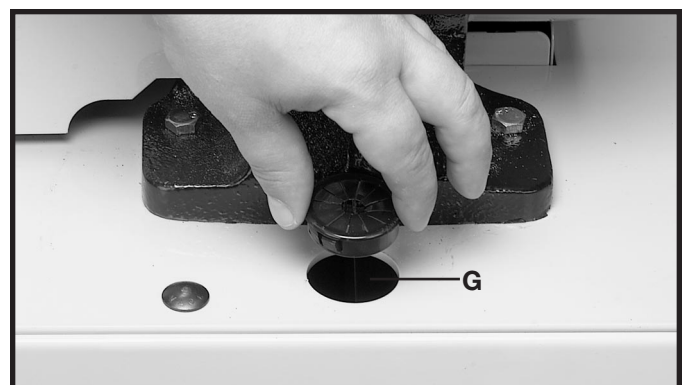

Fig. 38



7. Insert the switch cord (H) Fig. 39, through the hole in the cord bushing (G).

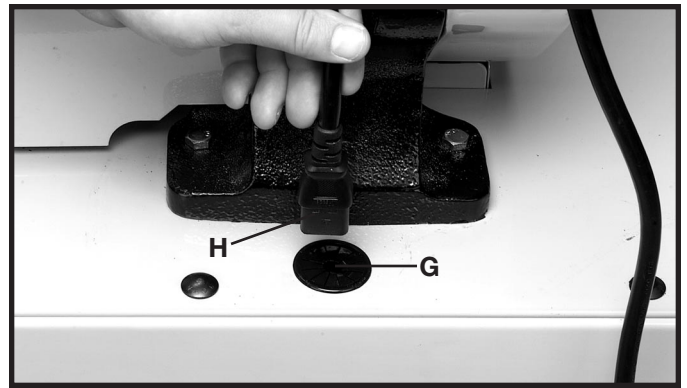

Fig. 39

8. Insert the pronged motor plug (J) Fig. 40, into the receptacle (H) of switch cord.

**CAUTION** MAKE SURE THAT THE MOTOR PLUG (J) FIG. 40 AND THE SWITCH CORD (H) ARE ROUTED BEHIND THE DUST CHUTE (K). IF THE BAND SAW IS BEING USED WITH THE ACCESSORY HEIGHT ATTACHMENT THE THE CORD HAS TO BE ROUTED IN FRONT OF THE DUST CHUTE.

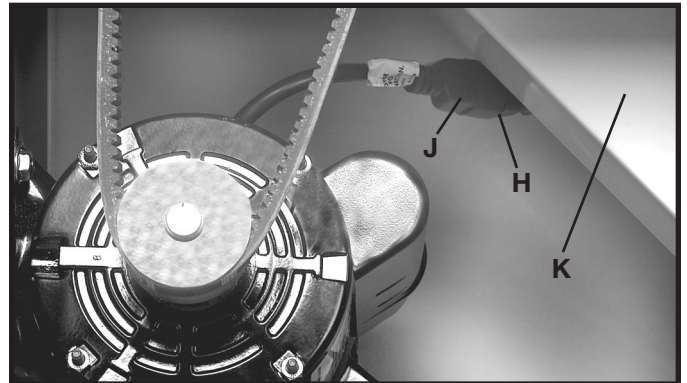

Fig. 40

## OPERATING CONTROLS AND ADJUSTMENTS

### STARTING AND STOPPING SAW

The power switch is located on the left side of the machine. To turn the machine “ON”, push the green start button (A) Fig. 41. To turn the machine “OFF”, push the red stop button (B).

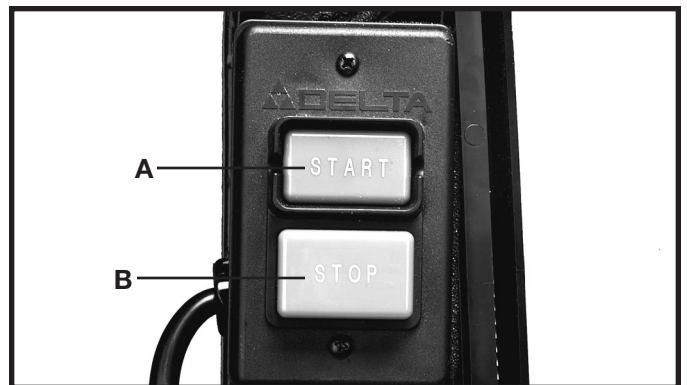

Fig. 41

### LOCKING SWITCH IN THE “OFF” POSITION

**IMPORTANT:** When the tool is not in use, the switch should be locked in the “OFF” position to prevent unauthorized use, using a padlock (C) Fig. 42 with a 3/16" diameter shackle.

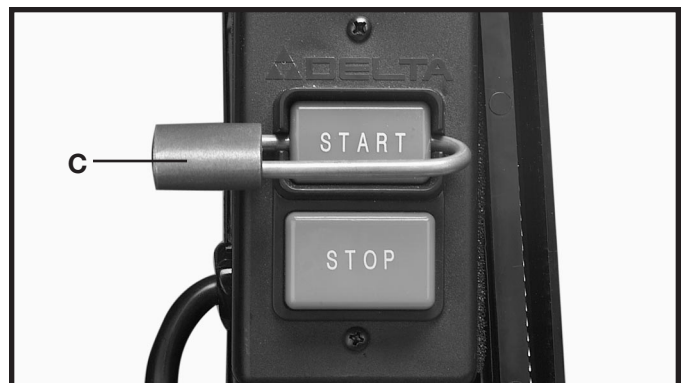

Fig. 42

# TILTING THE TABLE

**⚠ WARNING** DISCONNECT MACHINE FROM POWER SOURCE.

1. The table on the band saw can be tilted 45 degrees to the right and 8 degrees to the left. To tilt the table to the right, loosen the two clamp handles (A) Fig. 43, tilt the table to the desired angle as shown on the scale (D) Figs. 43 and 44, and tighten two locking handles (A) Fig. 43.

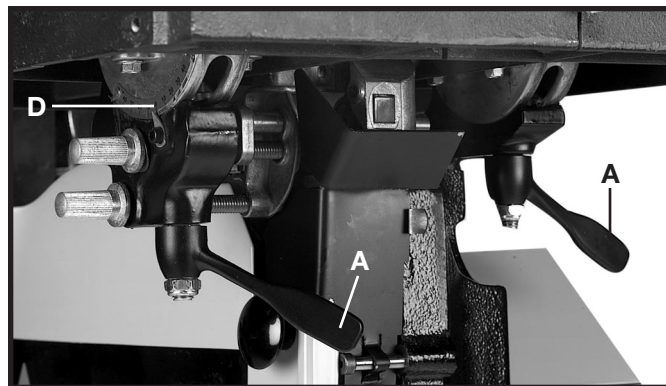

Fig. 43

2. To tilt the table to the left, loosen the two locking handles (A) Fig. 43, and tilt the table to the right until the table stops (B) Fig. 44 can be accessed. Rotate the table stop (B) Fig. 44, and tilt the table to the left. Tighten the two locking handles (A) Fig. 43.

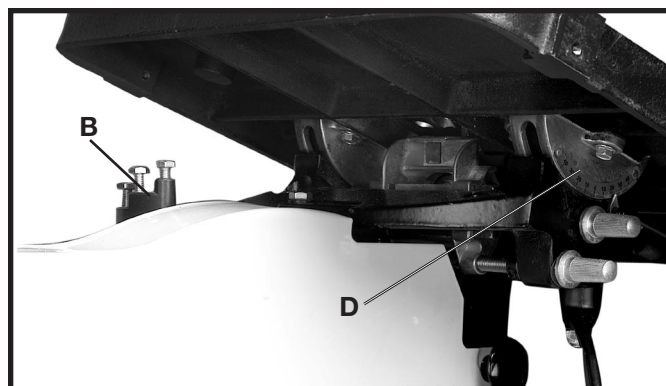

Fig. 44

# ADJUSTING THE TABLE STOPS

## To adjust the 90 degree stop

**⚠ WARNING** DISCONNECT MACHINE FROM POWER SOURCE.

1. Loosen the table clamp handles (A) Fig. 43, and tilt the table to the right.
2. Rotate the stop (B) Fig. 45 out of the way.
3. Place a square (G) Fig. 46, on the table and set blade square to table.
4. Clamp table handles (A) Fig. 43.
5. Rotate the stop (B) Fig. 45, until the tallest screw is under the table skirt.
6. Turn the screw up or down until the screw touches the table skirt.
7. Set pointer (J) Fig. 47 to "0" by loosening screw (K) Fig. 47, and move pointer (J) to the "0" degree mark, and tighten screw (K).

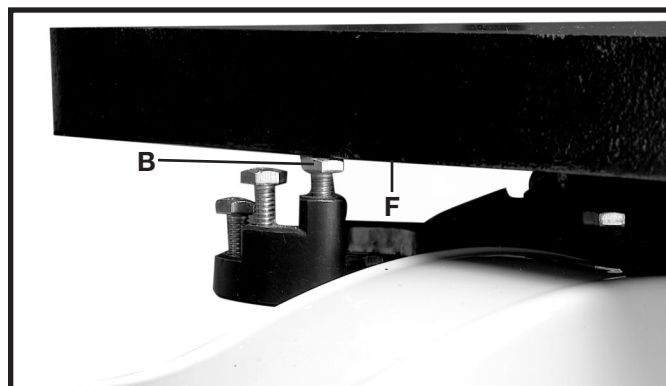

Fig. 45

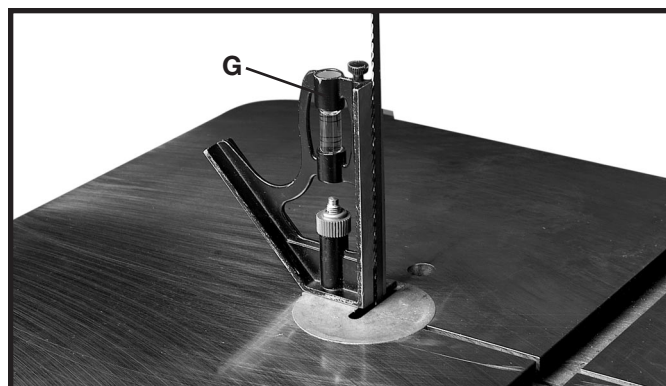

Fig. 46

## To set the adjustable stops:

**⚠ WARNING DISCONNECT MACHINE FROM POWER SOURCE.**

1. Loosen the two clamp handles (A) Fig. 43.
2. Tilt the table to the right, and turn the stop until either stop screw (M) or (N) Fig. 48, is under the table skirt.
3. Tilt the table to the left until it rests on the selected stop screw (M) or (N) Fig. 48.
4. The angle can be set by turning the stop screw and checking the angle on the side of the scale with pointer (J) Fig. 47.
5. Adjust the other stop screw in the same manner.

## ADJUSTING BLADE TENSION

**⚠ WARNING DISCONNECT MACHINE FROM POWER SOURCE.**

The band saw is equipped with a blade tension handle (A) Fig. 49. To apply tension, move the tension handle (A) to the left as shown. To release the blade tension, move the tension lever lock (B) Fig. 49 up, and move the tension handle (A) to the right as shown in Fig. 50.

To adjust the blade tension proceed as follows:

1. Push up on the blade tension lever lock (B) Fig. 49, move the blade tension handle to the right, to remove the blade tension.
2. The blade tension lever can be set for each of these blade widths 3/4", 1/2", 3/8", 1/4", and 1/8".
3. Make sure the blade tension lever is rotated to the right as far as possible. Pull out on the blade tension handle (A) Fig. 50, and turn the the tension lever until the appropriate width of the blade is shown on the top of the blade tension lever scale (C) and then release the blade tension lever handle so that the handle is contacting the hub (D).
4. Move the blade tension lever to the left until the lever lock (B) Fig. 49 engages the blade tension lever handle (A).

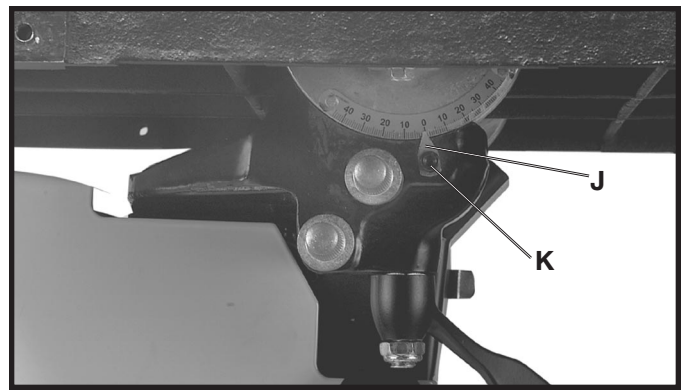

Fig. 47

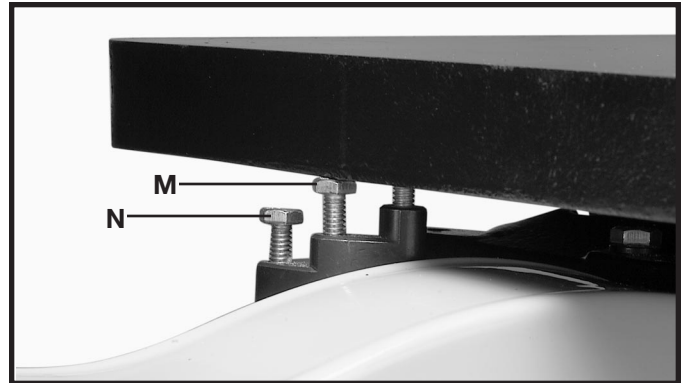

Fig. 48

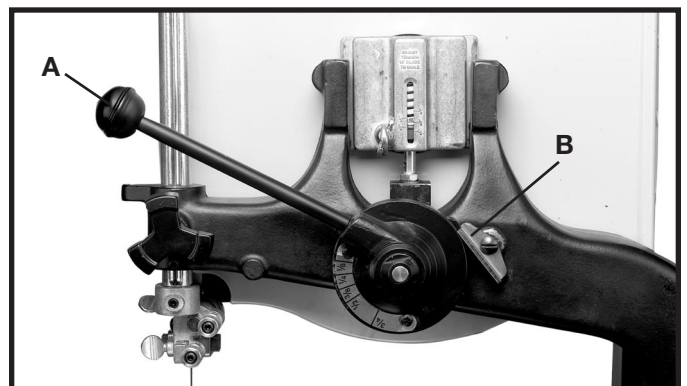

Fig. 49

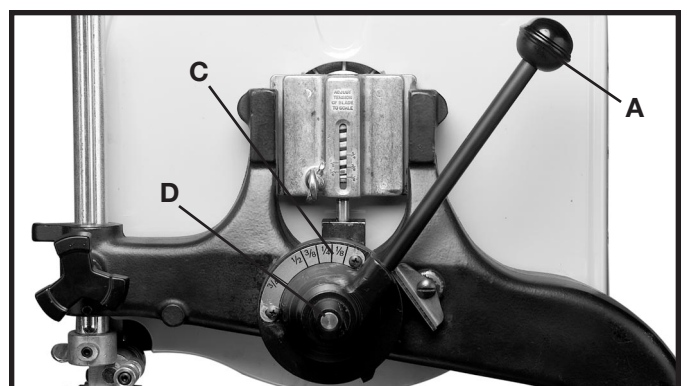

Fig. 50

5. The band saw blade tension can be fine tuned by turning adjustment nut (N) Fig. 51, while the blade is tensioned.

6. A series of graduations is located on the back of the upper wheel slide bracket (T) Fig. 51. These graduations indicate the proper tension for various widths of blades.

**NOTE: THESE GRADUATIONS ARE CORRECT FOR AVERAGE WORK, AND WILL NOT BE AFFECTED BY REBRAZING OF THE SAW BLADE.**

**CAUTION** WHEN CUTTING THIN PIECES, 3/4" OR LESS, SET THE BLADE TENSION BELOW THE MAXIMUM SETTING FOR BLADE WIDTH, TO EXTEND BLADE LIFE.

**CAUTION** OVER-STRAINING IS A COMMON CAUSE OF BLADE BREAKAGE AND OTHER UNSATISFACTORY BLADE PERFORMANCE. RELEASE THE TENSION WHEN THE TOOL IS NOT IN USE.

## TRACKING THE BLADE

**⚠ WARNING** DISCONNECT MACHINE FROM POWER SOURCE.

**CAUTION** BEFORE TRACKING THE BLADE, MAKE SURE THAT THE BLADE GUIDES AND BLADE SUPPORT BEARINGS ARE CLEAR OF THE BLADE.

After applying tension to the blade, rotate the wheels slowly forward by hand and observe the blade's movement. The blade (A) Fig. 52 should travel in the center of the upper tire. If the blade creeps toward the front edge, loosen the wing nut (B) Fig. 51, and turn the thumb screw (C) clockwise. This action draws the blade toward the center of the tire. If the blade creeps toward the back edge, turn the thumb screw in the opposite direction. Adjust the thumb screw (C) Fig. 51 only a fraction of a turn each time.

**⚠ WARNING** NEVER TRACK THE BLADE WHILE THE TOOL IS RUNNING.

After the blade is tracking in the center of the tires, tighten the wing nut (B) Fig. 51.

## VERTICAL ADJUSTMENT OF THE UPPER BLADE GUIDE ASSEMBLY

**⚠ WARNING** DISCONNECT MACHINE FROM POWER SOURCE.

Adjust the blade guides and bearings according to the following instructions.

Set the upper blade guide assembly (A) Fig. 53 as close as possible to the top surface of the workpiece. Loosen the lock knob (B) and move the guide assembly (A) to the desired position.

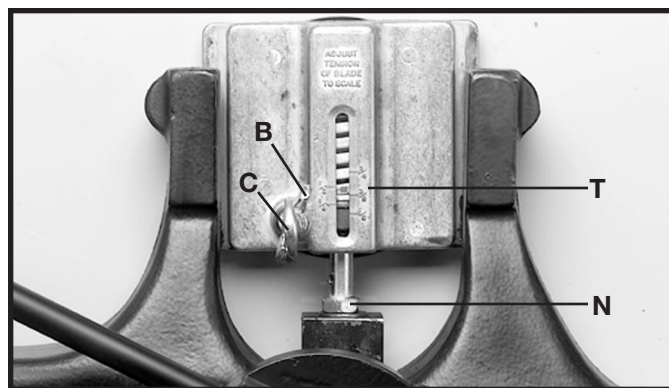

Fig. 51

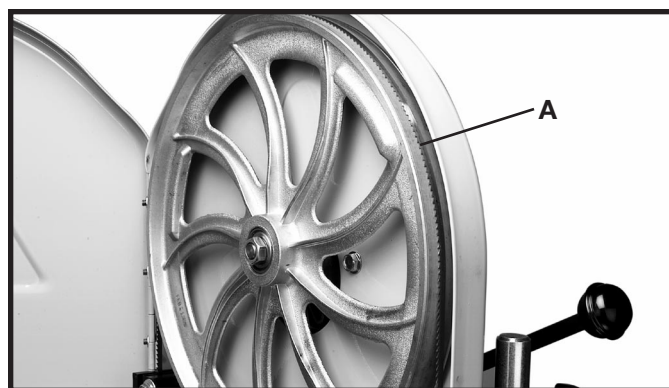

Fig. 52

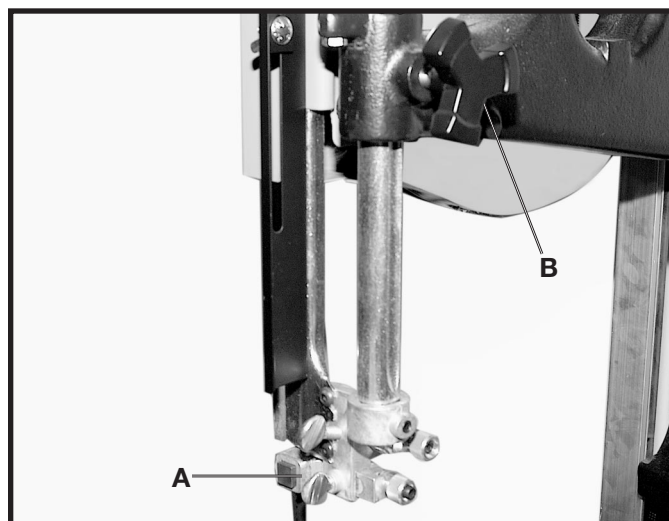

Fig. 53

# ADJUSTING THE UPPER BLADE GUIDES AND BLADE SUPPORT BEARING

Adjust the upper blade guides and blade support bearings **ONLY AFTER** the blade has the correct tension and is tracking properly. To adjust, do the following:

**⚠ WARNING DISCONNECT MACHINE FROM POWER SOURCE**

1. Make sure that the bottom blade guides and support bearings are not touching the blade.

2. Check the upper blade guide assembly. The blade guides (A) Fig. 54 should be parallel to the blade. To adjust, loosen the screw (B) and rotate the complete guide assembly (C). When the blade guides are parallel with the blade, tighten the screw (B).

3. Adjust the guides (A) Fig. 55 so that the front edge of the guides are just behind the “gullets” of the saw teeth. The complete guide block bracket can be moved in or out by loosening the thumb screw (C) and turning the knurled knob (D) Fig. 55. When the guides (A) are set properly, tighten thumb screw (C).

4. Two set screws (B) Fig. 55 hold the upper blade guides (A) in place. Loosen the set screws (B) to move the guides (A). Place them as close as possible to the side of the blade. (Be careful not to pinch the blade). Tighten the screws (B).

5. When the blade guide wears to a point that it cannot be adjusted close to the blade, loosen screw (B) Fig. 55 and reverse the blade guides (A) Fig. 55.

6. The upper blade support bearing (E) Fig. 55 prevents damage to the set in the saw teeth by keeping the blade from being pushed too far toward the back. The support bearing (E) should be set 1/64" behind the blade by loosening the thumb screw (F) and turning the knurled knob (G) to move the support bearing (E) in or out.

7. Adjust the blade support bearing (E) so that the back edge of the blade overlaps the outside diameter of the ball bearing by about 1/16". The bearing (E) is set on an eccentric. To change the position, remove the screw (H) and bearing (E) Fig. 55. Loosen the thumb screw (F), back out the knurled knob from the set screw. Remove the hex shaft from the hole, and rotate it to move the eccentric for the bearing.

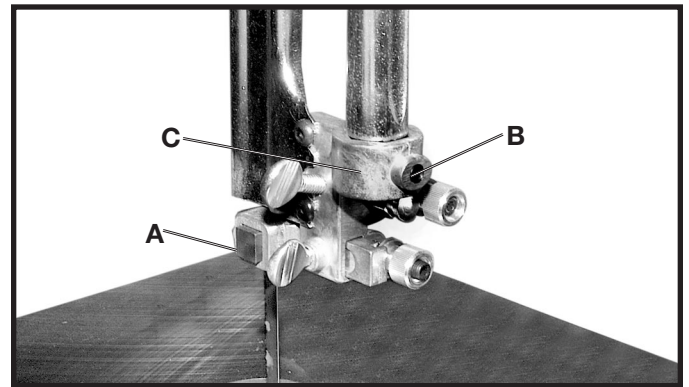

Fig. 54

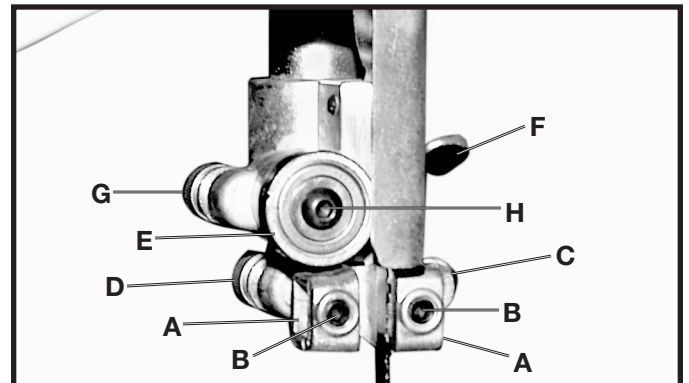

Fig. 55

# ADJUSTING LOWER BLADE GUIDES AND BLADE SUPPORT BEARING

Adjust the lower blade guides and blade support bearing after the upper guides and bearing have been adjusted.

**⚠ WARNING** DISCONNECT MACHINE FROM POWER SOURCE.

1. Adjust the front edge of the guide blocks (B) Fig. 56 so that they are just behind the “gullets” of the saw teeth. Turn the knurled knob (C) Fig. 56 to make this adjustment. Check the support bearing (D) Fig. 56. It should not be touching the back of the blade.
2. Loosen the two screws (A) Fig. 56. Move the guides (B) as close as possible to the side of the blade, being careful not to pinch the blade. Tighten screws (A).
3. Turn the other knurled knob (E) to adjust the lower blade support bearing (D) Fig. 56 so that it is about 1/64" behind the back of the blade.

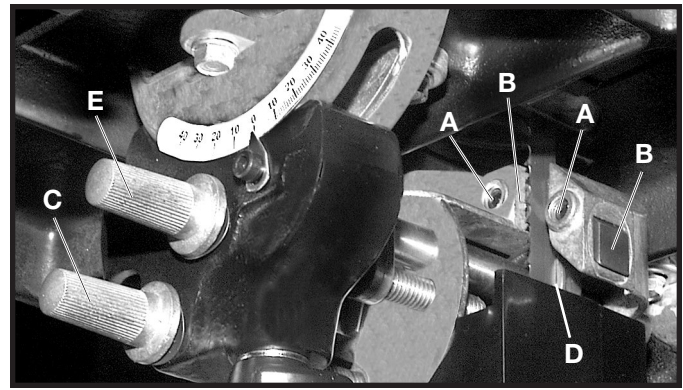

Fig. 56

## OPERATIONS

Before starting the machine, insure that all adjustments are properly made and the guards are in place. Turn the upper wheel by hand to make sure that everything is correct **BEFORE** turning on the power.

**⚠ WARNING** Keep the top blade guide (and guard) within 1/8" of the work piece at all times. Do not force the material against the blade. Light pressure on the work piece will produce a smoother cut, and prevent excess friction, and heating of the blade.

**KEEP THE SAW BLADE SHARP.** Very little forward pressure is required for normal cutting. Keep the workpiece moving at a slow and consistent rate against the blade to ensure a smooth and accurate cut.

Avoid twisting the blade, by trying not to turn sharp corners. Remember, you must saw around corners.

## CUTTING CURVES

When cutting curves, turn the stock carefully so that the blade follows without twisting. If a curve is so abrupt that it is necessary to repeatedly back up and cut a new kerf, a narrower blade, a blade with more set, or additional relief cuts Fig. 57, may be necessary to allow the blade to cut more efficiently. The more set a blade has, the easier it will allow the stock to be turned, but the cut is usually rougher.

When withdrawing the piece being cut, changing the cut, or for any other reason, be careful not to accidentally draw the blade off the wheels. In most cases, it is easier and safer to turn the stock and saw out through the waste material, rather than try to withdraw the stock from the blade.

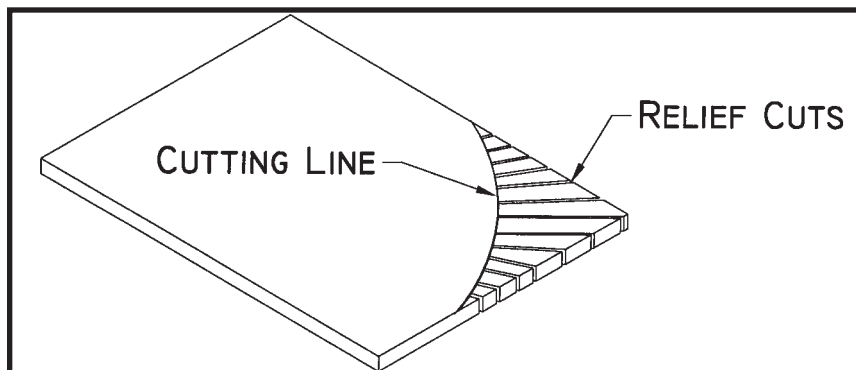

Fig. 57

# TROUBLESHOOTING GUIDE

In spite of how well a band saw is maintained, problems can occur. The following troubleshooting guide will help you solve the more common problems:

**Trouble:** *SAW WILL NOT START.*

**Probable Cause**

1. Switch cord / motor cord not plugged in.
2. Fuse blown or motor reset tripped.
3. Cord damaged.

**Remedy**

1. Plug in switch cord / motor cord.
2. Replace fuse or push motor reset button.
3. Have cord replaced.

**Trouble:** *BREAKER OR MOTOR KICKS OUT FREQUENTLY.*

**Probable Cause**

1. Extension cord too light or too long.
2. Feeding stock too fast.
3. Blade in poor condition (dull, warped, gummed).
4. Low voltage supply.

**Remedy**

1. Replace with adequate size cord.
2. Feed stock more slowly.
3. Clean or replace blade.
4. Contact an electrician.

**Trouble:** *BAND SAW VIBRATES EXCESSIVELY.*

**Probable Cause**

1. Machine not mounted securely to stand.
2. Stand on uneven surface.
3. Worn belt.
4. Pulley not aligned.
5. Motor not fastened securely.

**Remedy**

1. Tighten all mounting hardware.
2. Reposition on flat level surface.
3. Replace belt.
4. Adjust motor pulley.
5. Tighten all mounting hardware.

**Trouble:** *BAND SAW DOES NOT COME UP TO SPEED.*

**Probable Cause**

1. Low voltage due to improper extension cord size.
2. Low voltage.
3. Motor wired for incorrect voltage.

**Remedy**

1. Replace with adequate size cord.
2. Contact an electrician.
3. Rewire motor for correct voltage.

**Trouble:** *BLADES BREAK.*

**Probable Cause**

1. Blade not tensioned properly.
2. Blade guides improperly adjusted.
3. Blade support bearing improperly adjusted.
4. Blade wheel tracking adjustment improperly set.
5. Bad weld on blade.
6. Worn tires.
7. Forcing wide blade around short radius.
8. Dull blade or insufficient set.
9. Upper blade guide set too high.
10. Continuous running of machine when not actually cutting.

**Remedy**

1. Adjust blade tension.
2. Check and adjust blade guides.
3. Adjust blade support bearing.
4. Check and adjust blade tracking.
5. Replace the blade.
6. Replace tires.
7. Change to a narrower blade.
8. Replace blade.
9. Set upper blade guide within 1/8" of workpiece.
10. Turn off machine when not performing cutting operation.

*(continued on next page)*

**Trouble:** *BLADE WILL NOT TRACK.*

**Probable Cause**

1. Blade too loose
2. Upper wheel not properly adjusted.
3. Improperly adjusted blade support bearing.

**Remedy**

1. Adjust tension
2. Adjust upper wheel.
3. Adjust blade support bearing.

**Trouble:** *CUT DOES NOT AGREE WITH SETTING ON THE TILT SCALE.*

**Probable Cause**

1. Pointer out of adjustment

**Remedy**

1. Adjust pointer.

**Trouble:** *BLADE WILL NOT STAY ON WHEEL.*

**Probable Cause**

1. Blade not tensioned properly.
2. Blade guides improperly adjusted.
3. Blade support bearing improperly adjusted.
4. Blade wheel not tracking properly.
5. Bad weld on blade.
6. Worn tires.

**Remedy**

1. Adjust blade tension.
2. Check and adjust blade guides.
3. Adjust blade support bearing.
4. Check and adjust blade tracking.
5. Replace the blade.
6. Replace tires.

**Trouble:** *BAND SAW MAKES UNSATISFACTORY CUTS.*

**Probable Cause**

1. Blade not tensioned properly.
2. Blade guides improperly adjusted.
3. Blade support bearing improperly set.
4. Blade wheel not tracking properly.
5. Bad weld on blade.
6. Worn tires.
7. Incorrect blade for work being done.
8. Dull blade or insufficient set.
9. Upper blade guide set too high.

**Remedy**

1. Adjust blade tension.
2. Check and adjust blade guides.
3. Adjust blade support bearing.
4. Check and adjust blade tracking.
5. Replace the blade.
6. Replace tires.
7. Change the blade.
8. Replace blade.
9. Set upper blade guide within 1/8" of work piece.



# BAND SAW BLADES

A band saw blade is a delicate piece of steel that is subjected to tremendous strain. You can obtain long use from a band saw blade if you use it properly. Be sure you use blades of the proper thickness, width and temper for the various types of material and cuts.

Always use the widest blade possible. Use narrow blades only for sawing small, abrupt curves and for fine, delicate work. This will save blades and will produce better cuts. For cutting wood and similar materials, Delta offers blades in widths of 1/8", 1/4", 3/8", 1/2", and 3/4".

Any one of a number of conditions may cause a band saw blade to break. Blade breakage is, in some cases, unavoidable, being the natural result of the peculiar stresses to which blades are subjected. Blades will break often due to avoidable causes, such as the lack of care to the blade or the blade not being properly adjusted to the band saw. The most common causes of blade breakage are:

- (1) faulty alignments and adjustments of the guides.
- (2) forcing or twisting a wide blade around a curve of short radius.
- (3) feeding the work piece too fast into the blade.
- (4) dullness of the teeth, or absence of sufficient set.
- (5) improperly tensioned blade.
- (6) top guide set too high above the work piece being cut.
- (7) using a blade with a lumpy or improperly finished braze or weld.
- (8) continuous running of the saw blade when not cutting.

Use blades that are 93½" in length on this machine.

Always use a sharp blade. Keep it free from gum and pitch. Clean frequently with a stiff fiber brush.

Narrow blades are used for cutting small circles or curves while the wider blades are best suited for straight cutting such as ripping.

A new blade, in most cases, will perform better and last longer than a re-sharpened blade.

Insure that the blade guides are adjusted properly.

Do not force or twist the blade around a curve or a very short radius.

Feed the workpiece through the blade at a consistent rate, allow the blade to do the cutting – do not feed the work piece too fast.

Do not apply excessive tension to the blade. The tension is only necessary to drive the blade without slipping on the wheels. Narrow blades require less tension than wider blades.

# NOTES

# ACCESSORIES

A complete line of accessories is available from your Delta Supplier, Porter-Cable • Delta Factory Service Centers, and Delta Authorized Service Stations. Please visit our Web Site [www.deltamachinery.com](http://www.deltamachinery.com) for a catalog or for the name of your nearest supplier.

**▲WARNING** Since accessories other than those offered by Delta have not been tested with this product, use of such accessories could be hazardous. For safest operation, only Delta recommended accessories should be used with this product.



## PARTS, SERVICE OR WARRANTY ASSISTANCE

All Delta Machines and accessories are manufactured to high quality standards and are serviced by a network of Porter-Cable • Delta Factory Service Centers and Delta Authorized Service Stations. To obtain additional information regarding your Delta quality product or to obtain parts, service, warranty assistance, or the location of the nearest service outlet, please call 1-800-223-7278 (In Canada call 1-800-463-3582).



### Two Year Limited New Product Warranty

Delta will repair or replace, at its expense and at its option, any new Delta machine, machine part, or machine accessory which in normal use has proven to be defective in workmanship or material, provided that the customer returns the product prepaid to a Delta factory service center or authorized service station with proof of purchase of the product within two years and provides Delta with reasonable opportunity to verify the alleged defect by inspection. For all refurbished Delta product, the warranty period is 180 days. Delta may require that electric motors be returned prepaid to a motor manufacturer's authorized station for inspection and repair or replacement. Delta will not be responsible for any asserted defect which has resulted from normal wear, misuse, abuse or repair or alteration made or specifically authorized by anyone other than an authorized Delta service facility or representative. Under no circumstances will Delta be liable for incidental or consequential damages resulting from defective products. This warranty is Delta's sole warranty and sets forth the customer's exclusive remedy, with respect to defective products; all other warranties, express or implied, whether of merchantability, fitness for purpose, or otherwise, are expressly disclaimed by Delta.

## PORTER-CABLE • DELTA SERVICE CENTERS (CENTROS DE SERVICIO DE PORTER-CABLE • DELTA)

Parts and Repair Service for Porter-Cable • Delta Machinery are Available at These Locations  
(Obtenga Refaccion de Partes o Servicio para su Herramienta en los Siguietes Centros de Porter-Cable • Delta)

### ARIZONA

Tempe 85282 (Phoenix)  
2400 West Southern Avenue  
Suite 105  
Phone: (602) 437-1200  
Fax: (602) 437-2200

### CALIFORNIA

Ontario 91761 (Los Angeles)  
3949A East Guasti Road  
Phone: (909) 390-5555  
Fax: (909) 390-5554

San Leandro 94577 (Oakland)  
3039 Teagarden Street  
Phone: (510) 357-9762  
Fax: (510) 357-7939

### COLORADO

Arvada 80003 (Denver)  
8175 Sheridan Blvd., Unit S  
Phone: (303) 487-1809  
Fax: (303) 487-1868

### FLORIDA

Davie 33314 (Miami)  
4343 South State Rd. 7 (441)  
Unit #107  
Phone: (954) 321-6635  
Fax: (954) 321-6638

Tampa 33609  
4538 W. Kennedy Boulevard  
Phone: (813) 877-9585  
Fax: (813) 289-7948

### GEORGIA

Forest Park 30297 (Atlanta)  
5442 Frontage Road,  
Suite 112  
Phone: (404) 608-0006  
Fax: (404) 608-1123

### ILLINOIS

Addison 60101 (Chicago)  
400 South Rohlwing Rd.  
Phone: (630) 424-8805  
Fax: (630) 424-8895  
  
Woodridge 60517 (Chicago)  
2033 West 75th Street  
Phone: (630) 910-9200  
Fax: (630) 910-0360

### MARYLAND

Elkridge 21075 (Baltimore)  
7397-102 Washington Blvd.  
Phone: (410) 799-9394  
Fax: (410) 799-9398

### MASSACHUSETTS

Braintree 02185 (Boston)  
719 Granite Street  
Phone: (781) 848-9810  
Fax: (781) 848-6759

Franklin 02038 (Boston)  
Franklin Industrial Park  
101E Constitution Blvd.  
Phone: (508) 520-8802  
Fax: (508) 528-8089

### MICHIGAN

Madison Heights 48071 (Detroit)  
30475 Stephenson Highway  
Phone: (248) 597-5000  
Fax: (248) 597-5004

### MINNESOTA

Minneapolis 55429  
5522 Lakeland Avenue North  
Phone: (763) 561-9080  
Fax: (763) 561-0653

### MISSOURI

North Kansas City 64116  
1141 Swift Avenue  
Phone: (816) 221-2070  
Fax: (816) 221-2897

St. Louis 63119  
7574 Watson Road  
Phone: (314) 968-8950  
Fax: (314) 968-2790

### NEW YORK

Flushing 11365-1595 (N.Y.C.)  
175-25 Horace Harding Expwy.  
Phone: (718) 225-2040  
Fax: (718) 423-9619

### NORTH CAROLINA

Charlotte 28270  
9129 Monroe Road, Suite 115  
Phone: (704) 841-1176  
Fax: (704) 708-4625

### OHIO

Columbus 43214  
4560 Indianola Avenue  
Phone: (614) 263-0929  
Fax: (614) 263-1238

Cleveland 44125  
8001 Sweet Valley Drive  
Unit #19  
Phone: (216) 447-9030  
Fax: (216) 447-3097

### OREGON

Portland 97230  
4916 NE 122 nd Ave.  
Phone: (503) 252-0107  
Fax: (503) 252-2123

### PENNSYLVANIA

Willow Grove 19090  
520 North York Road  
Phone: (215) 658-1430  
Fax: (215) 658-1433

### TEXAS

Carrollton 75006 (Dallas)  
1300 Interstate 35 N, Suite 112  
Phone: (972) 446-2996  
Fax: (972) 446-8157

Houston 77055  
West 10 Business Center  
1008 Wirt Road, Suite 120  
Phone: (713) 682-0334  
Fax: (713) 682-4867

### WASHINGTON

Auburn 98001 (Seattle)  
3320 West Valley HWY, North  
Building D, Suite 111  
Phone: (253) 333-8353  
Fax: (253) 333-9613

Authorized Service Stations are located in many large cities. Telephone **800-438-2486** or **731-541-6042** for assistance locating one. Parts and accessories for Porter-Cable-Delta products should be obtained by contacting any Porter-Cable-Delta Distributor, Authorized Service Center, or Porter-Cable-Delta Factory Service Center. If you do not have access to any of these, call **800-223-7278** and you will be directed to the nearest Porter-Cable-Delta Factory Service Center. Las Estaciones de Servicio Autorizadas están ubicadas en muchas grandes ciudades. Llame al **800-438-2486** ó al **731-541-6042** para obtener asistencia a fin de localizar una. Las piezas y los accesorios para los productos Porter-Cable-Delta deben obtenerse poniéndose en contacto con cualquier distribuidor Porter-Cable-Delta, Centro de Servicio Autorizado o Centro de Servicio de Fábrica Porter-Cable-Delta. Si no tiene acceso a ninguna de estas opciones, llame al **800-223-7278** y le dirigirán al Centro de Servicio de Fábrica Porter-Cable-Delta más cercano.

## CANADIAN PORTER-CABLE • DELTA SERVICE CENTERS

### ALBERTA

Bay 6, 2520-23rd St. N.E.  
Calgary, Alberta  
T2E 8L2  
Phone: (403) 735-6166  
Fax: (403) 735-6144

### BRITISH COLUMBIA

8520 Baxter Place  
Burnaby, B.C.  
V5A 4T8  
Phone: (604) 420-0102  
Fax: (604) 420-3522

### MANITOBA

1699 Dublin Avenue  
Winnipeg, Manitoba  
R3H 0H2  
Phone: (204) 633-9259  
Fax: (204) 632-1976

### ONTARIO

505 Southgate Drive  
Guelph, Ontario  
N1H 6M7  
Phone: (519) 836-2840  
Fax: (519) 767-4131

### QUÉBEC

1515 ave.  
St-Jean Baptiste,  
Québec, Québec  
G2E 5E2  
Phone: (418) 877-7112  
Fax: (418) 877-7123

1447, Begin  
St-Laurent, (Montréal),  
Québec  
H4R 1V8  
Phone: (514) 336-8772  
Fax: (514) 336-3505

The following are trademarks of PORTER-CABLE-DELTA (Las siguientes son marcas registradas de PORTER-CABLE S.A.): Auto-Set®, BAMMER®, B.O.S.S.®, Builder's Saw®, Contractor's Saw®, Contractor's Saw II™, Delta®, DELTACRAFT®, DELTAGRAM™, Delta Series 2000™, DURATRONIC™, Emc<sup>2</sup>™, FLEX®, Flying Chips™, FRAME SAW®, Homecraft®, INNOVATION THAT WORKS®, Jet-Lock®, JETSTREAM®, 'kickstand', LASERLOC®, MICRO-SET®, Micro-Set®, MIDI LATHE®, MORTEN™, NETWORK™, OMNIJIG®, POCKET CUTTER®, PORTA-BAND®, PORTA-PLANE®, PORTER-CABLE®(design), PORTER-CABLE®PROFESSIONAL POWER TOOLS, Posi-Matic®, Q-3®(design), QUICKSAND®(design), QUICKSET™, QUICKSET II®, QUICKSET PLUS™, RIPTIDE™(design), SAFE GUARD II®, SAFE-LOC®, Sanding Center®, SANDTRAP®(design), SAW BOSS®, Sawbuck™, Sidekick®, SPEED-BLOC®, SPEEDMATIC®, SPEEDTRONIC®, STAIR EASE®, The American Woodshop®(design), The Lumber Company®(design), THE PROFESSIONAL EDGE®, THE PROFESSIONAL SELECT®, THIN-LINE™, TIGER®, TIGER CUB®, TIGER SAW®, TORQBUSTER®, TORQ-BUSTER®, TRU-MATCH™, TWIN-LITE®, UNIGUARD®, Unifence®, UNIFEEDER™, Unihead®, Uniplane™, Unirip®, Unisaw®, Univise®, Versa-Feeder®, VERSA-PLANE®, WHISPER SERIES®, WOODWORKER'S CHOICE™.

Trademarks noted with ™ and ® are registered in the United States Patent and Trademark Office and may also be registered in other countries. Las Marcas Registradas con el signo de ™ y ® son registradas por la Oficina de Registros y Patentes de los Estados Unidos y también pueden estar registradas en otros países.